

# HT/HTD T11 Series High Torque Unit

- Available in AC and DC versions
- Output Torque: Up to 50Nm depending on speed and motor size
- Speed Range: 0.35 - 5rpm

The FB/FBD T3 can be fitted with an additional external gearbox. This produces a unit that can give extremely slow rpm and very high torque. High quality engineering ensures quiet running and a long running life.

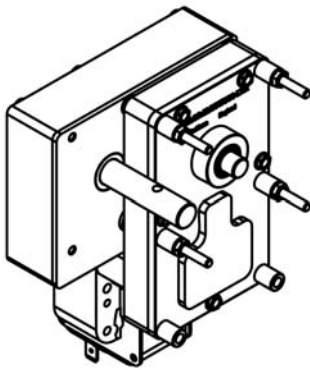

HT T11 Series

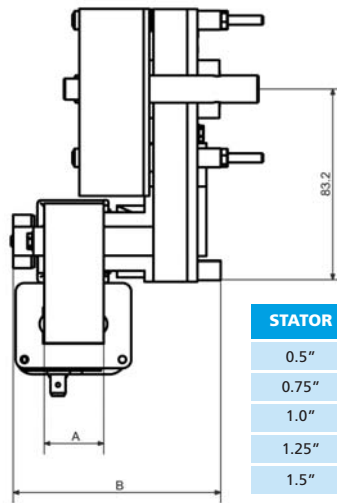

STATOR	A	B
0.5"	13.0	78.0
0.75"	19.0	84.0
1.0"	25.0	90.0
1.25"	32.0	97.0
1.5"	38.0	103.0

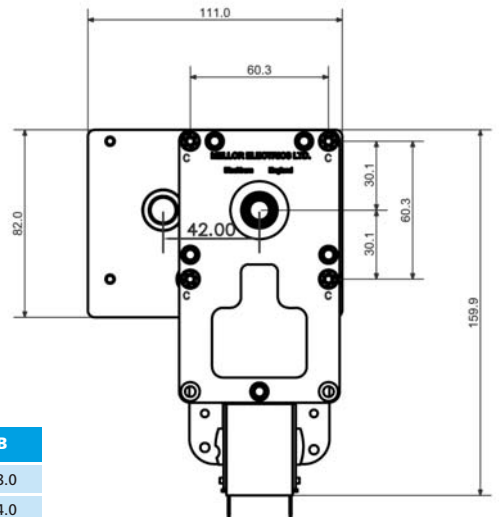

4 mounting positions (C)  
M4 thread

Applicable to all models

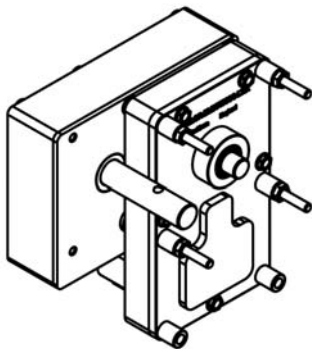

HTD T11 Series

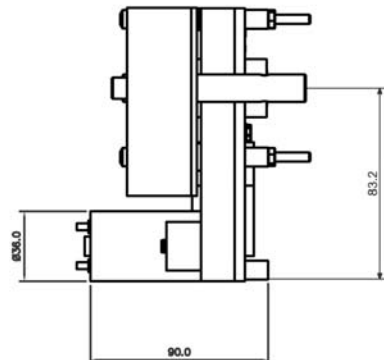

**Mellor**  
ELECTRICS LIMITED